

Introduction - Geometry

The following released test questions are taken from the Geometry Standards Test. This test is one of the California Standards Tests administered as part of the Standardized Testing and Reporting (STAR) Program under policies set by the State Board of Education.

All questions on the California Standards Tests are evaluated by committees of content experts, including teachers and administrators, to ensure their appropriateness for measuring the California academic content standards in Geometry. In addition to content, all items are reviewed and approved to ensure their adherence to the principles of fairness and to ensure no bias exists with respect to characteristics such as gender, ethnicity, and language.

This document contains released test questions from the California Standards Test forms in 2003, 2004, 2005, 2006, and 2007. First on the pages that follow are lists of the standards assessed on the Geometry Test. Next are released test questions. Following the questions is a table that gives the correct answer for each question, the content standard that each question is measuring, and the year each question last appeared on the test.

The following table lists each reporting cluster, the number of items that appear on the exam, and the number of released test questions that appear in this document. Some of the released test questions for Geometry are the same test questions found in different combinations on the Integrated Mathematics 1, 2, and 3 California Standards Tests and the Summative High School Mathematics California Standards Test.

REPORTING CLUSTER	NUMBER OF QUESTIONS ON EXAM	NUMBER OF RELEASED TEST QUESTIONS
Logic and Geometric Proofs	23	27
Volume and Area Formulas	11	14
Angle Relationships, Constructions, and Lines	16	20
Trigonometry	15	19
TOTAL	65	80

In selecting test questions for release, three criteria are used: (1) the questions adequately cover a selection of the academic content standards assessed on the Geometry Test; (2) the questions demonstrate a range of difficulty; and (3) the questions present a variety of ways standards can be assessed. These released test questions do not reflect all of the ways the standards may be assessed. Released test questions will not appear on future tests.

For more information about the California Standards Tests, visit the California Department of Education's Web site at <http://www.cde.ca.gov/ta/tg/sr/resources.asp>.

THE LOGIC AND GEOMETRIC PROOFS REPORTING CLUSTER

The following seven California content standards are included in the Logic and Geometric Proofs reporting cluster and are represented in this booklet by 27 test questions. These questions represent only some ways in which these standards may be assessed on the Geometry California Mathematics Standards Test.

CALIFORNIA CONTENT STANDARDS IN THIS REPORTING CLUSTER

Geometry	
GE1.0*	Students demonstrate understanding by identifying and giving examples of undefined terms, axioms, theorems, and inductive and deductive reasoning.
GE2.0*	Students write geometric proofs, including proofs by contradiction.
GE3.0*	Students construct and judge the validity of a logical argument and give counterexamples to disprove a statement.
GE4.0*	Students prove basic theorems involving congruence and similarity.
GE5.0	Students prove that triangles are congruent or similar, and they are able to use the concept of corresponding parts of congruent triangles.
GE6.0	Students know and are able to use the triangle inequality theorem.
GE7.0*	Students prove and use theorems involving the properties of parallel lines cut by a transversal, the properties of quadrilaterals, and the properties of circles.

* Denotes key standards

THE VOLUME AND AREA FORMULAS REPORTING CLUSTER

The following four California content standards are included in the Volume and Area Formulas reporting cluster and are represented in this booklet by 14 test questions. These questions represent only some ways in which these standards may be assessed on the Geometry California Mathematics Standards Test.

CALIFORNIA CONTENT STANDARDS IN THIS REPORTING CLUSTER

Geometry

GE8.0*	Students know, derive, and solve problems involving perimeter, circumference, area, volume, lateral area, and surface area of common geometric figures.
GE9.0	Students compute the volumes and surface areas of prisms, pyramids, cylinders, cones, and spheres; and students commit to memory the formulas for prisms, pyramids, and cylinders.
GE10.0*	Students compute areas of polygons, including rectangles, scalene triangles, equilateral triangles, rhombi, parallelograms, and trapezoids.
GE11.0	Students determine how changes in dimensions affect the perimeter, area, and volume of common geometric figures and solids.

* Denotes key standards

THE ANGLE RELATIONSHIPS, CONSTRUCTIONS, AND LINES REPORTING CLUSTER

The following six California content standards are included in the Angle Relationships, Constructions, and Lines reporting cluster and are represented in this booklet by 20 test questions. These questions represent only some ways in which these standards may be assessed on the Geometry California Mathematics Standards Test.

CALIFORNIA CONTENT STANDARDS IN THIS REPORTING CLUSTER

Geometry

GE12.0*	Students find and use measures of sides and of interior and exterior angles of triangles and polygons to classify figures and solve problems.
GE13.0	Students prove relationships between angles in polygons by using properties of complementary, supplementary, vertical, and exterior angles.
GE14.0*	Students prove the Pythagorean theorem.
GE15.0	Students use the Pythagorean theorem to determine distance and find missing lengths of sides of right triangles.
GE16.0*	Students perform basic constructions with a straightedge and compass, such as angle bisectors, perpendicular bisectors, and the line parallel to a given line through a point off the line.
GE17.0*	Students prove theorems by using coordinate geometry, including the midpoint of a line segment, the distance formula, and various forms of equations of lines and circles.

* Denotes key standards

THE TRIGONOMETRY REPORTING CLUSTER

The following five California content standards are included in the Trigonometry reporting cluster and are represented in this booklet by 19 test questions. These questions represent only some ways in which these standards may be assessed on the Geometry California Mathematics Standards Test.

CALIFORNIA CONTENT STANDARDS IN THIS REPORTING CLUSTER

Geometry

GE18.0*	Students know the definitions of the basic trigonometric functions defined by the angles of a right triangle. They also know and are able to use elementary relationships between them. For example, $\tan(x) = \sin(x)/\cos(x)$, $(\sin(x))^2 + (\cos(x))^2 = 1$.
GE19.0*	Students use trigonometric functions to solve for an unknown length of a side of a right triangle, given an angle and a length of a side.
GE20.0	Students know and are able to use angle and side relationships in problems with special right triangles, such as 30° , 60° , and 90° triangles and 45° , 45° , and 90° triangles.
GE21.0*	Students prove and solve problems regarding relationships among chords, secants, tangents, inscribed angles, and inscribed and circumscribed polygons of circles.
GE22.0*	Students know the effect of rigid motions on figures in the coordinate plane and space, including rotations, translations, and reflections.

* Denotes key standards

Geometry

Released Test Questions

1 Which of the following best describes deductive reasoning?

- A using logic to draw conclusions based on accepted statements
- B accepting the meaning of a term without definition
- C defining mathematical terms to correspond with physical objects
- D inferring a general truth by examining a number of specific examples

CSG00185

2 In the diagram below, $\angle 1 \cong \angle 4$.

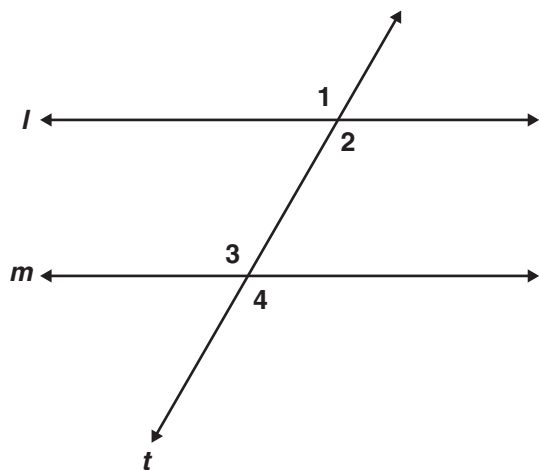

Which of the following conclusions does *not* have to be true?

- A $\angle 3$ and $\angle 4$ are supplementary angles.
- B Line l is parallel to line m .
- C $\angle 1 \cong \angle 3$
- D $\angle 2 \cong \angle 3$

CSG10066

3 Consider the arguments below.

- I. Every multiple of 4 is even. 376 is a multiple of 4. Therefore, 376 is even.
- II. A number can be written as a repeating decimal if it is rational. Pi cannot be written as a repeating decimal. Therefore, pi is not rational.

Which one(s), if any, use deductive reasoning?

- A I only
- B II only
- C both I and II
- D neither I nor II

CSG00552

4 Theorem: A triangle has at most one obtuse angle.

Eduardo is proving the theorem above by contradiction. He began by assuming that in $\triangle ABC$, $\angle A$ and $\angle B$ are both obtuse. Which theorem will Eduardo use to reach a contradiction?

- A If two angles of a triangle are equal, the sides opposite the angles are equal.
- B If two supplementary angles are equal, the angles each measure 90° .
- C The largest angle in a triangle is opposite the longest side.
- D The sum of the measures of the angles of a triangle is 180° .

CSG00025

- 5 Use the proof to answer the question below.

Given: $\overline{AB} \cong \overline{BC}$; D is the midpoint of \overline{AC}

Prove: $\triangle ABD \cong \triangle CBD$

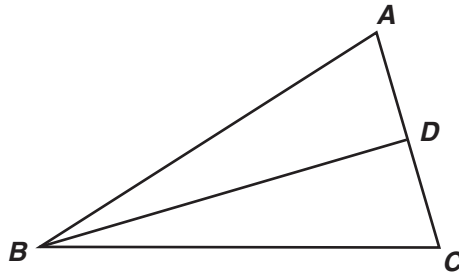

<u>Statement</u>	<u>Reason</u>
1. $\overline{AB} \cong \overline{BC}$; D is the midpoint of \overline{AC}	1. Given
2. $\overline{AD} \cong \overline{CD}$	2. Definition of Midpoint
3. $\overline{BD} \cong \overline{BD}$	3. Reflexive Property
4. $\triangle ABD \cong \triangle CBD$	4. ?

What reason can be used to prove that the triangles are congruent?

- A AAS
- B ASA
- C SAS
- D SSS

Geometry

Released Test Questions

- 6 In the figure below, $AB > BC$.

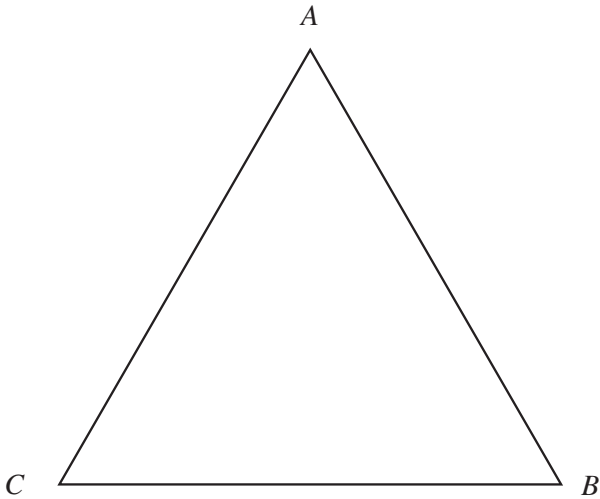

If we assume that $m\angle A = m\angle C$, it follows that $AB = BC$. This contradicts the given statement that $AB > BC$. What conclusion can be drawn from this contradiction?

- A $m\angle A = m\angle B$
- B $m\angle A \neq m\angle B$
- C $m\angle A = m\angle C$
- D $m\angle A \neq m\angle C$

CSG00524

- 7 Use the proof to answer the question below.

Given: $\angle 2 \cong \angle 3$

Prove: $\angle 1 \cong \angle 4$

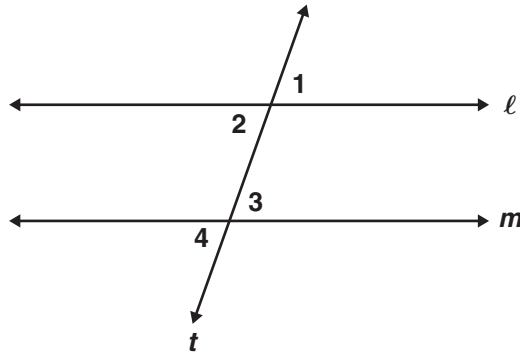

<u>Statement</u>	<u>Reason</u>
1. $\angle 2 \cong \angle 3$	1. Given
2. $\angle 1 \cong \angle 2; \angle 3 \cong \angle 4$	2. ?
3. $\angle 1 \cong \angle 4$	3. Transitive Property

What reason can be used to justify statement 2?

- A Complements of congruent angles are congruent.
- B Vertical angles are congruent.
- C Supplements of congruent angles are congruent.
- D Corresponding angles are congruent.

CSG10069

Geometry

Released Test Questions

- 8** “Two lines in a plane always intersect in exactly one point.”

Which of the following best describes a counterexample to the assertion above?

- A coplanar lines
- B parallel lines
- C perpendicular lines
- D intersecting lines

CSG00320

- 9** Which figure can serve as a counterexample to the conjecture below?

If one pair of opposite sides of a quadrilateral is parallel, then the quadrilateral is a parallelogram.

- A rectangle
- B rhombus
- C square
- D trapezoid

CSG10194

- 10** Given: $TRAP$ is an isosceles trapezoid with diagonals \overline{RP} and \overline{TA} . Which of the following *must* be true?

- A $\overline{RP} \perp \overline{TA}$
- B $\overline{RP} \parallel \overline{TA}$
- C $\overline{RP} \cong \overline{TA}$
- D \overline{RP} bisects \overline{TA}

CSG00260

- 11** A conditional statement is shown below.

If a quadrilateral has perpendicular diagonals, then it is a rhombus.

Which of the following is a counterexample to the statement above?

A



C

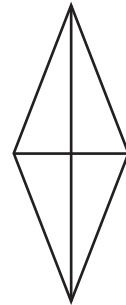

B

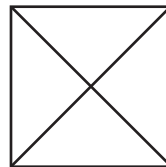

D

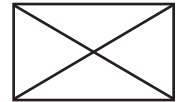

CSG20216

Released Test Questions

Geometry

12 Which triangles must be similar?

- A two obtuse triangles
- B two scalene triangles with congruent bases
- C two right triangles
- D two isosceles triangles with congruent vertex angles

CSG00578

13 Which of the following facts would be sufficient to prove that triangles ABC and DBE are similar?

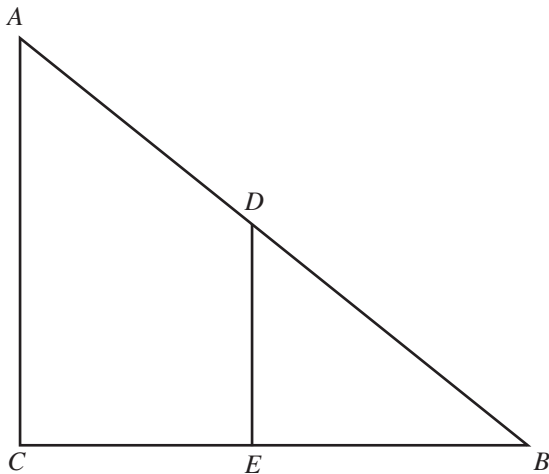

- A \overline{CE} and \overline{BE} are congruent.
- B $\angle ACE$ is a right angle.
- C \overline{AC} and \overline{DE} are parallel.
- D $\angle A$ and $\angle B$ are congruent.

CSG00544

14 Parallelogram $ABCD$ is shown below.

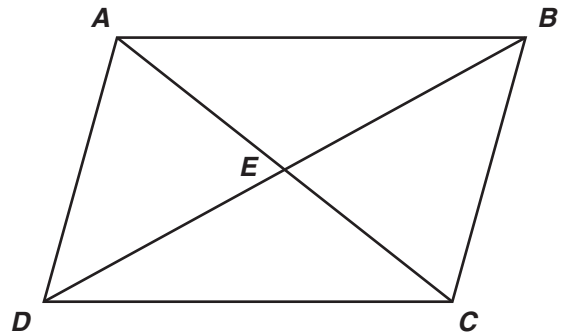

Which pair of triangles can be established to be congruent to prove that $\angle DAB \cong \angle BCD$?

- A $\triangle ADC$ and $\triangle BCD$
- B $\triangle AED$ and $\triangle BEC$
- C $\triangle DAB$ and $\triangle BCD$
- D $\triangle DEC$ and $\triangle BEA$

CSG10146

15 If $\triangle ABC$ and $\triangle XYZ$ are two triangles such that $\frac{AB}{XY} = \frac{BC}{YZ}$, which of the following would be sufficient to prove the triangles are similar?

- A $\angle A \cong \angle X$
- B $\angle B \cong \angle Y$
- C $\angle C \cong \angle Z$
- D $\angle X \cong \angle Y$

CSG10218

Geometry

Released Test Questions

16 In parallelogram $FGHI$, diagonals \overline{IG} and \overline{FH} are drawn and intersect at point M . Which of the following statements *must* be true?

- A $\triangle FGI$ must be an obtuse triangle.
- B $\triangle HIG$ must be an acute triangle.
- C $\triangle FMG$ must be congruent to $\triangle HMG$.
- D $\triangle GMH$ must be congruent to $\triangle IMF$.

CSG00559

17 Which of the following *best* describes the triangles shown below?

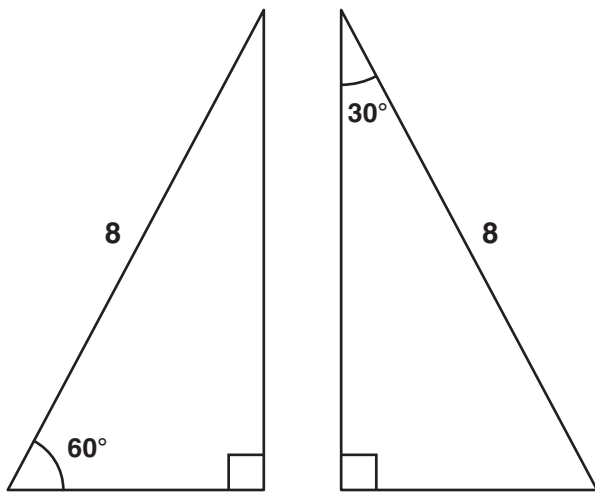

- A both similar and congruent
- B similar but not congruent
- C congruent but not similar
- D neither similar nor congruent

CSG00478

18 Which of the following statements must be true if $\triangle GHI \sim \triangle JKL$?

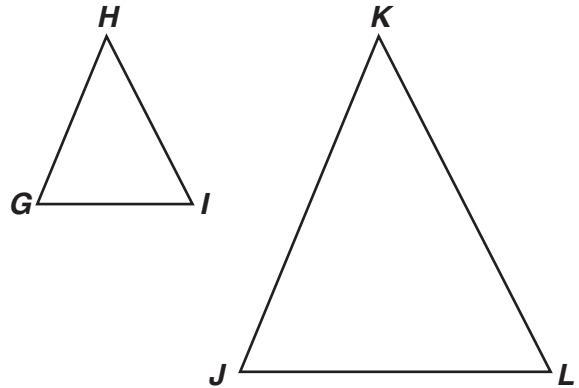

- A The two triangles must be scalene.
- B The two triangles must have exactly one acute angle.
- C At least one of the sides of the two triangles must be parallel.
- D The corresponding sides of the two triangles must be proportional.

CSG20074

Released Test Questions

Geometry

19 In the figure below, $\overline{AC} \cong \overline{DF}$ and $\angle A \cong \angle D$.

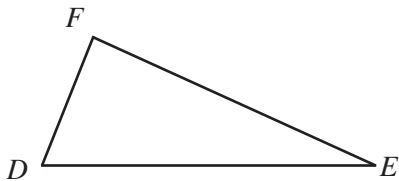
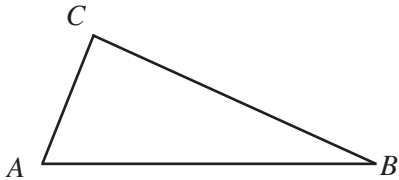

Which additional information would be enough to prove that $\triangle ABC \cong \triangle DEF$?

- A $\overline{AB} \cong \overline{DE}$
- B $\overline{AB} \cong \overline{BC}$
- C $\overline{BC} \cong \overline{EF}$
- D $\overline{BC} \cong \overline{DE}$

CSG00517

20 Given: \overline{AB} and \overline{CD} intersect at point E ;
 $\angle 1 \cong \angle 2$

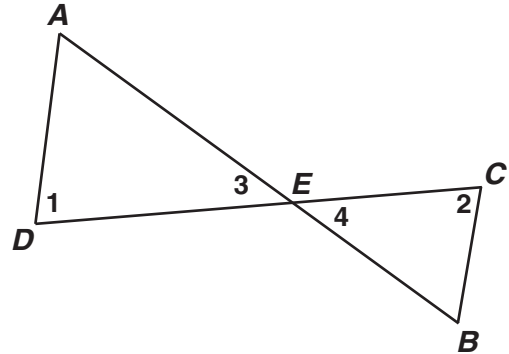

Which theorem or postulate can be used to prove $\triangle AED \sim \triangle BEC$?

- A AA
- B SSS
- C ASA
- D SAS

CSG10074

21 In the figure below, n is a whole number. What is the *smallest* possible value for n ?

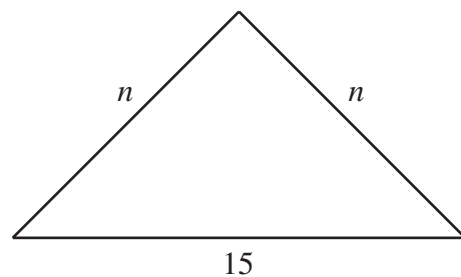

- A 1
- B 7
- C 8
- D 14

CSG00295

Geometry

Released Test Questions

- 22** Which of the following sets of numbers could represent the lengths of the sides of a triangle?

- A 2, 2, 5
- B 3, 3, 5
- C 4, 4, 8
- D 5, 5, 15

CSG10041

- 23** In the accompanying diagram, parallel lines l and m are cut by transversal t .

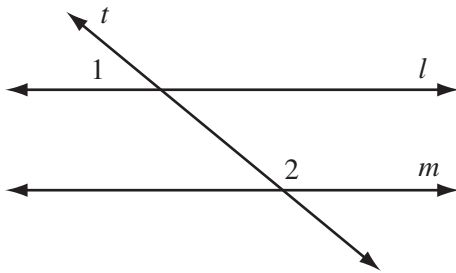

Which statement about angles 1 and 2 *must* be true?

- A $\angle 1 \cong \angle 2$.
- B $\angle 1$ is the complement of $\angle 2$.
- C $\angle 1$ is the supplement of $\angle 2$.
- D $\angle 1$ and $\angle 2$ are right angles.

CSG00579

- 24** What values of a and b make quadrilateral $MNOP$ a parallelogram?

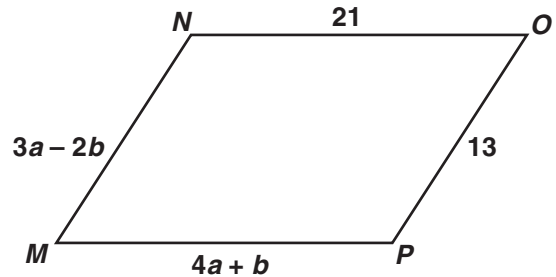

- A $a = 1, b = 5$
- B $a = 5, b = 1$
- C $a = \frac{11}{7}, b = \frac{34}{7}$
- D $a = \frac{34}{7}, b = \frac{11}{7}$

CSG10163

- 25** Quadrilateral $ABCD$ is a parallelogram. If adjacent angles are congruent, which statement *must* be true?

- A Quadrilateral $ABCD$ is a square.
- B Quadrilateral $ABCD$ is a rhombus.
- C Quadrilateral $ABCD$ is a rectangle.
- D Quadrilateral $ABCD$ is an isosceles trapezoid.

CSG20048

Released Test Questions

Geometry

- 26 For the quadrilateral shown below, what is $m\angle a + m\angle c$?

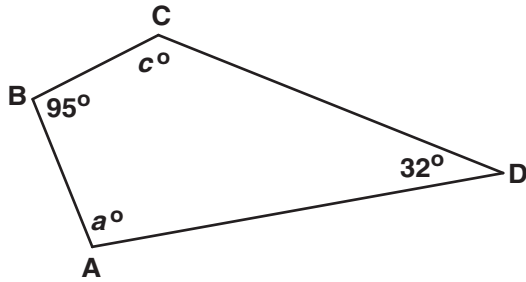

- A 53°
- B 137°
- C 180°
- D 233°

CSG10162

- 27 If $ABCD$ is a parallelogram, what is the length of segment BD ?

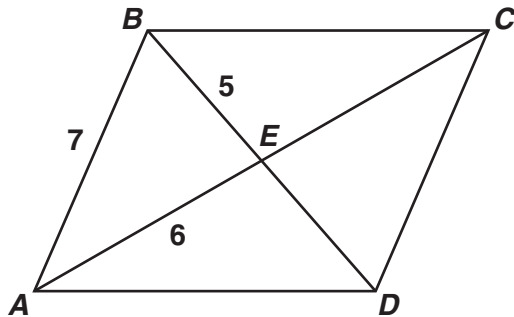

- A 10
- B 11
- C 12
- D 14

CSG20236

- 28 A right circular cone has radius 5 inches and height 8 inches.

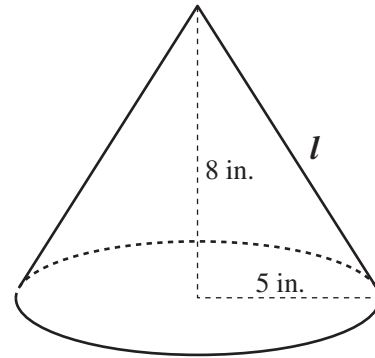

What is the lateral area of the cone? (Lateral area of cone = πrl , where l = slant height)

- A 40π sq in.
- B 445π sq in.
- C $5\pi\sqrt{39}$ sq in.
- D $5\pi\sqrt{89}$ sq in.

CSG00053

Geometry

Released Test Questions

- 29** Figure $ABCD$ is a kite.

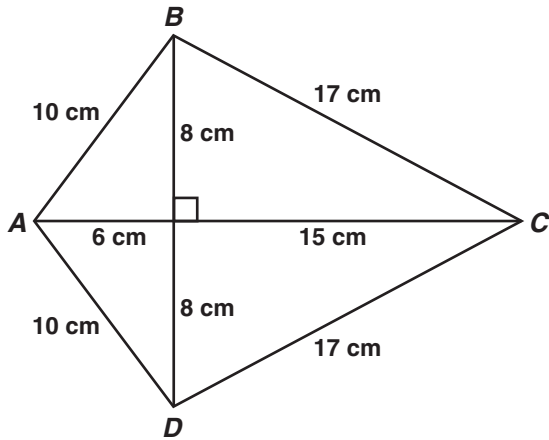

What is the area of figure $ABCD$, in square centimeters?

- A 120
- B 154
- C 168
- D 336

CSG20157

- 30** If a cylindrical barrel measures 22 inches in diameter, how many inches will it roll in 8 revolutions along a smooth surface?

- A 121π in.
- B 168π in.
- C 176π in.
- D 228π in.

CSG00564

- 31** A sewing club is making a quilt consisting of 25 squares with each side of the square measuring 30 centimeters. If the quilt has five rows and five columns, what is the perimeter of the quilt?

- A 150 cm
- B 300 cm
- C 600 cm
- D 900 cm

CSG20111

- 32** The four sides of this figure will be folded up and taped to make an open box.

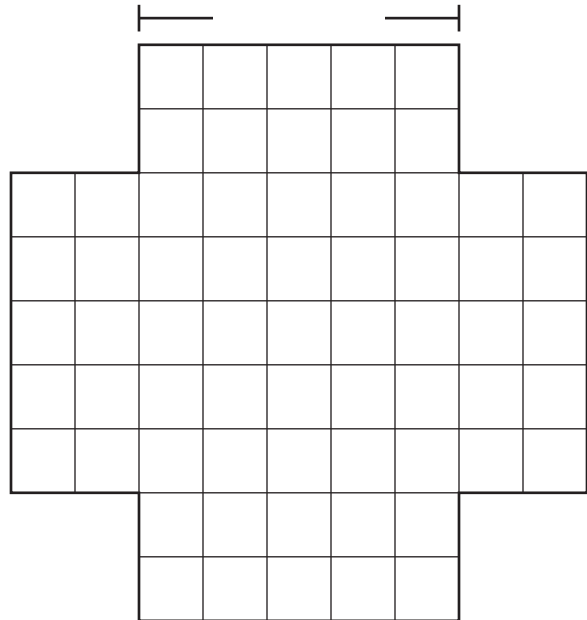

What will be the volume of the box?

- A 50 cm^3
- B 75 cm^3
- C 100 cm^3
- D 125 cm^3

CSG00299

Released Test Questions

Geometry

- 33** A classroom globe has a diameter of 18 inches.



Which of the following is the approximate surface area, in square inches, of the globe?
(Surface Area = $4\pi r^2$)

- A 113.0
- B 226.1
- C 254.3
- D 1017.4

CSG20238

- 34** The rectangle shown below has length 20 meters and width 10 meters.

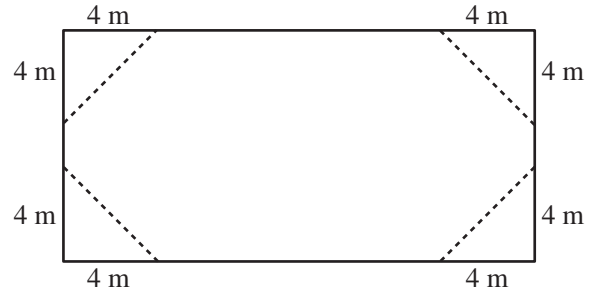

If four triangles are removed from the rectangle as shown, what will be the area of the remaining figure?

- A 136 m^2
- B 144 m^2
- C 168 m^2
- D 184 m^2

CSG00012

- 35** If $RSTW$ is a rhombus, what is the area of $\triangle WXT$?

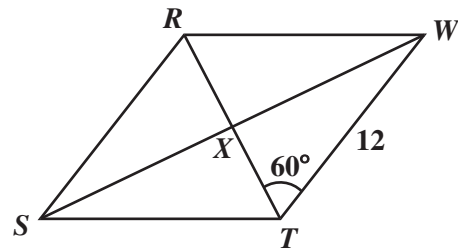

- A $18\sqrt{3}$
- B $36\sqrt{3}$
- C 36
- D 48

CSG00027

Geometry

Released Test Questions

- 36** What is the area, in square units, of the trapezoid shown below?

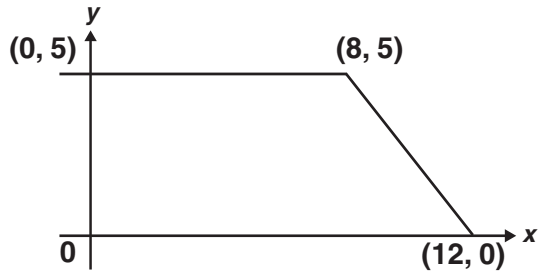

- A 37.5
- B 42.5
- C 50
- D 100

CSG20226

- 37** The figure below is a square with four congruent parallelograms inside.

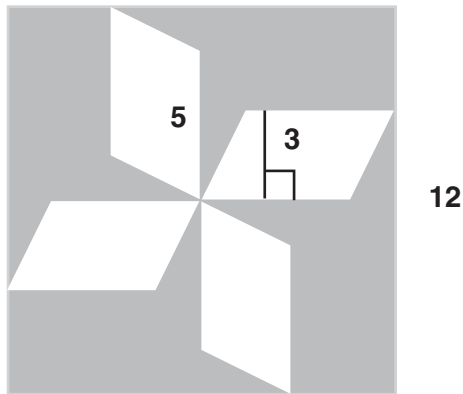

What is the area, in square units, of the shaded portion?

- A 60
- B 84
- C 114
- D 129

CSG20225

- 38** What is the area, in square meters (m), of the trapezoid shown below?

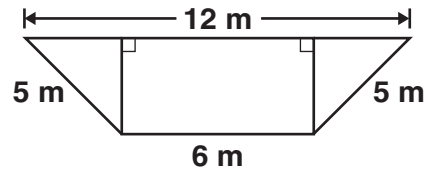

- A 28
- B 36
- C 48
- D 72

CSG10047

- 39** What is the area, in square inches (in.), of the triangle below?

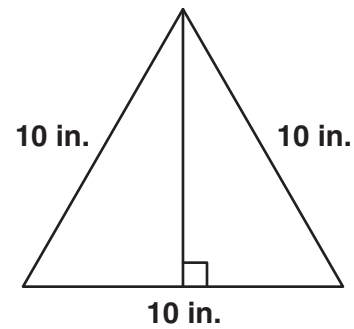

- A 25
- B $25\sqrt{3}$
- C 50
- D $50\sqrt{3}$

CSG10048

Released Test Questions

Geometry

- 40** The perimeters of two squares are in a ratio of 4 to 9. What is the ratio between the areas of the two squares?

A 2 to 3
 B 4 to 9
 C 16 to 27
 D 16 to 81

CSG00013

- 41** Lea made two candles in the shape of right rectangular prisms. The first candle is 15 cm high, 8 cm long, and 8 cm wide. The second candle is 5 cm higher but has the same length and width. How much additional wax was needed to make the taller candle?

A 320 cm^3
 B 640 cm^3
 C 960 cm^3
 D 1280 cm^3

CSG20116

- 42** Two angles of a triangle have measures of 55° and 65° . Which of the following could *not* be a measure of an exterior angle of the triangle?

A 115°
 B 120°
 C 125°
 D 130°

CSG00571

- 43** The sum of the interior angles of a polygon is the same as the sum of its exterior angles. What type of polygon is it?

A quadrilateral
 B hexagon
 C octagon
 D decagon

CSG00305

- 44** What is $m\angle x$?

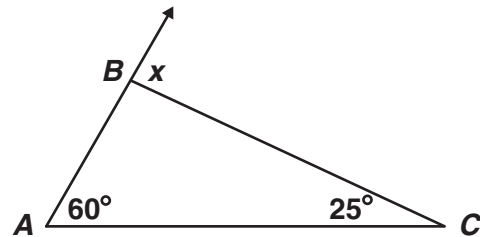

A 35°
 B 60°
 C 85°
 D 95°

CSG20086

- 45** If the measure of an exterior angle of a regular polygon is 120° , how many sides does the polygon have?

A 3
 B 4
 C 5
 D 6

CSG20204

Geometry

Released Test Questions

- 46 In the figure below, $\overline{AB} \parallel \overline{CD}$.

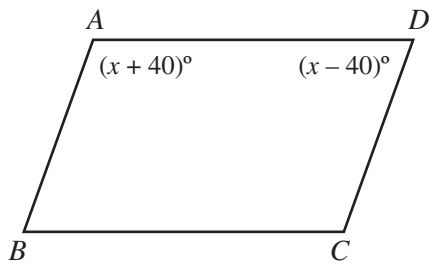

What is the value of x ?

- A 40
- B 50
- C 80
- D 90

CSG00244

- 47 The measures of the interior angles of a pentagon are $2x$, $6x$, $4x - 6$, $2x - 16$, and $6x + 2$. What is the measure, in degrees, of the largest angle?

- A 28
- B 106
- C 170
- D 174

CSG10028

- 48 What is $m\angle 1$?

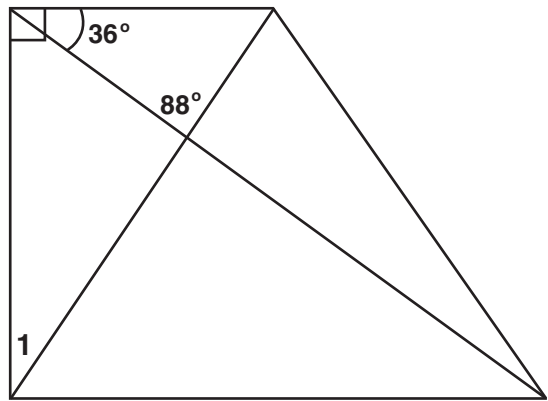

- A 34°
- B 56°
- C 64°
- D 92°

CSG20179

- 49 What is $m\angle WZX$?

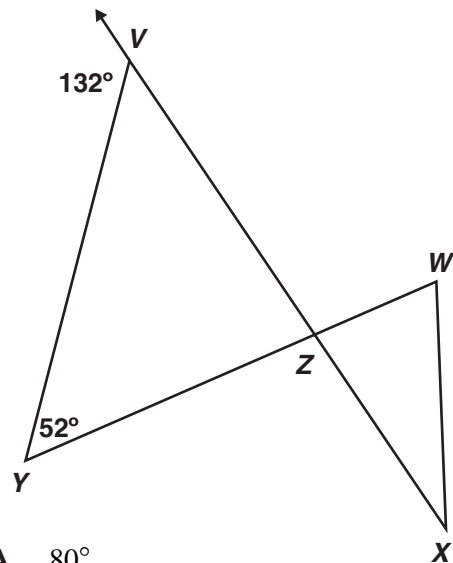

- A 80°
- B 90°
- C 100°
- D 110°

CSG30022

Released Test Questions

Geometry

- 50** What is the measure of an exterior angle of a regular hexagon?

A 30°
 B 60°
 C 120°
 D 180°

CSG00570

- 51** A diagram from a proof of the Pythagorean theorem is pictured below.

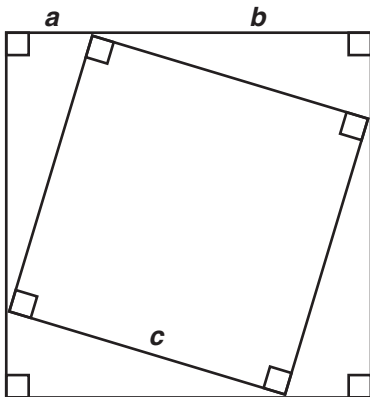

Which statement would *not* be used in the proof of the Pythagorean theorem?

- A The area of a triangle equals $\frac{1}{2}ab$.
 B The four right triangles are congruent.
 C The area of the inner square is equal to half of the area of the larger square.
 D The area of the larger square is equal to the sum of the areas of the smaller square and the four congruent triangles.

CSG10192

- 52** A right triangle's hypotenuse has length 5. If one leg has length 2, what is the length of the other leg?

A 3
 B $\sqrt{21}$
 C $\sqrt{29}$
 D 7

CSG00566

- 53** A new pipeline is being constructed to re-route its oil flow around the exterior of a national wildlife preserve. The plan showing the old pipeline and the new route is shown below.

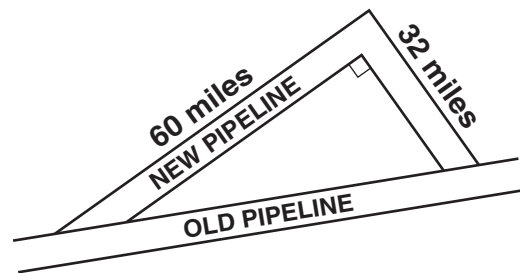

About how many extra miles will the oil flow once the new route is established?

- A 24
 B 68
 C 92
 D 160

CSG10016

Geometry

Released Test Questions

- 54** Marsha is using a straightedge and compass to do the construction shown below.

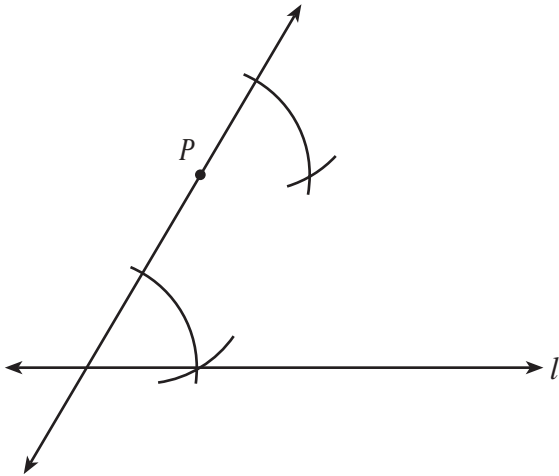

Which *best* describes the construction Marsha is doing?

- A a line through P parallel to line l
- B a line through P intersecting line l
- C a line through P congruent to line l
- D a line through P perpendicular to line l

CSG00526

- 55** Given: angle A

What is the first step in constructing the angle bisector of angle A ?

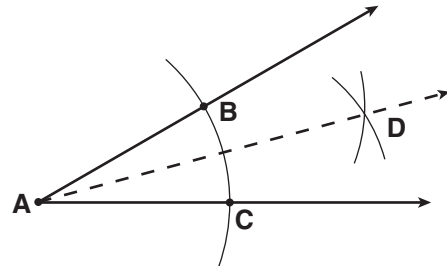

- A Draw ray \overline{AD} .
- B Draw a line segment connecting points B and C .
- C From points B and C , draw equal arcs that intersect at D .
- D From point A , draw an arc that intersects the sides of the angle at points B and C .

CSG10131

- 56** Scott is constructing a line perpendicular to line l from point P . Which of the following should be his first step?

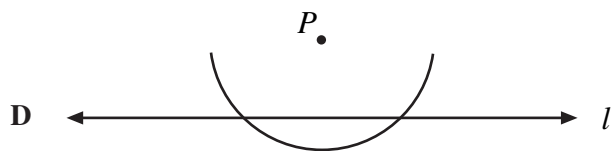
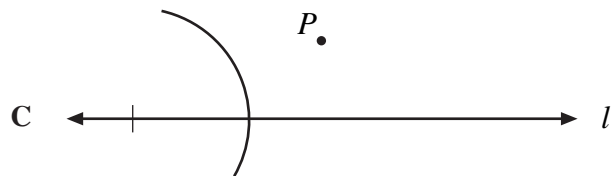
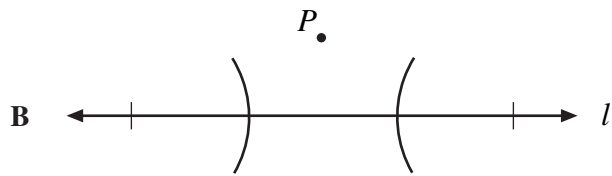
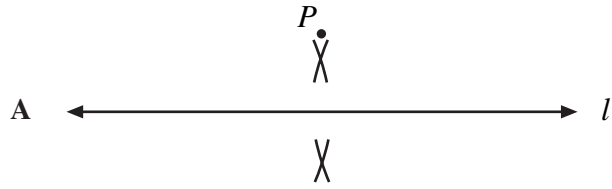

CSG00308

- 57** Which triangle can be constructed using the following steps?

1. Put the tip of the compass on point A .
2. Open the compass so that the pencil tip is on point B .
3. Draw an arc above \overline{AB} .
4. Without changing the opening, put the metal tip on point B and draw an arc intersecting the first arc at point C .
5. Draw \overline{AC} and \overline{BC} .

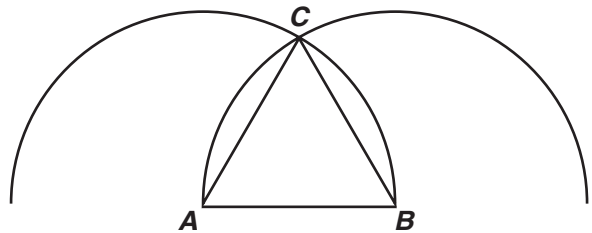

- A** right
- B** obtuse
- C** scalene
- D** equilateral

CSG10135

Geometry

Released Test Questions

- 58** The diagram shows $\triangle ABC$.

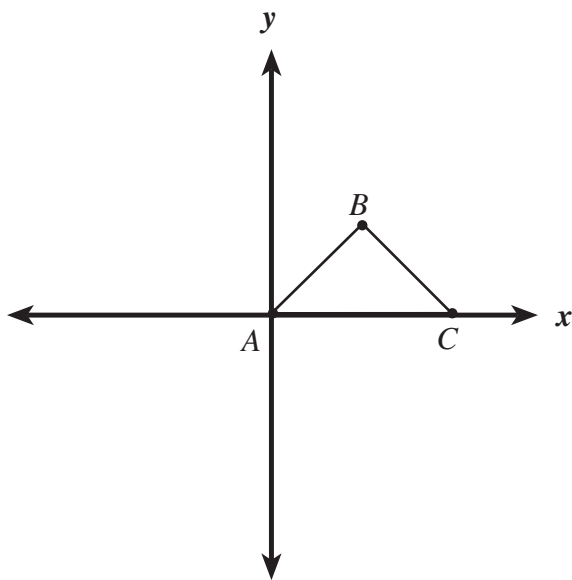

Which statement would prove that $\triangle ABC$ is a right triangle?

- A $(\text{slope } \overline{AB})(\text{slope } \overline{BC}) = 1$
 B $(\text{slope } \overline{AB})(\text{slope } \overline{BC}) = -1$
 C distance from A to B = distance from B to C
 D distance from A to B = $-$ (distance from B to C)

CSG00475

- 59** Figure $ABCO$ is a parallelogram.

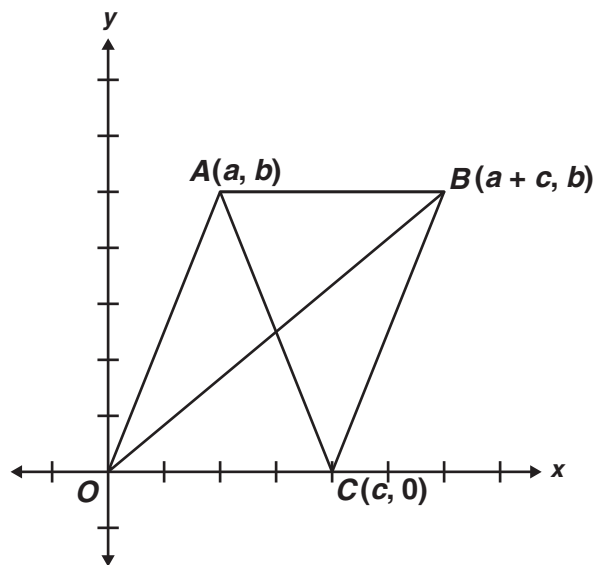

What are the coordinates of the point of intersection of the diagonals?

- A $\left(\frac{a}{2}, \frac{b}{2}\right)$
 B $\left(\frac{c}{2}, \frac{b}{2}\right)$
 C $\left(\frac{a+c}{2}, \frac{b}{2}\right)$
 D $\left(\frac{a+c}{2}, \frac{a+b}{2}\right)$

CSG20101

Released Test Questions

Geometry

- 60** What type of triangle is formed by the points $A(4,2)$, $B(6,-1)$, and $C(-1,3)$?

A right
 B equilateral
 C isosceles
 D scalene

CSG10235

- 61** The point $(-3, 2)$ lies on a circle whose equation is $(x + 3)^2 + (y + 1)^2 = r^2$. Which of the following must be the radius of the circle?

A 3
 B $\sqrt{10}$
 C 9
 D 10

CSG30048

- 62** In the figure below, if $\sin x = \frac{5}{13}$, what are $\cos x$ and $\tan x$?

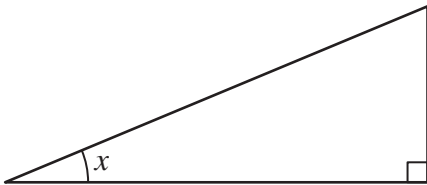

- A $\cos x = \frac{12}{13}$ and $\tan x = \frac{5}{12}$
 B $\cos x = \frac{12}{13}$ and $\tan x = \frac{12}{5}$
 C $\cos x = \frac{13}{12}$ and $\tan x = \frac{5}{12}$
 D $\cos x = \frac{13}{12}$ and $\tan x = \frac{13}{5}$

CSG00493

- 63** In the figure below, $\sin A = 0.7$.

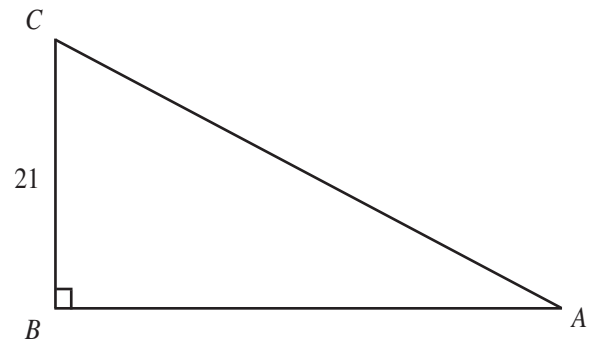

What is the length of \overline{AC} ?

- A 14.7
 B 21.7
 C 30
 D 32

CSG00432

Geometry

Released Test Questions

- 64 Approximately how many feet tall is the streetlight?

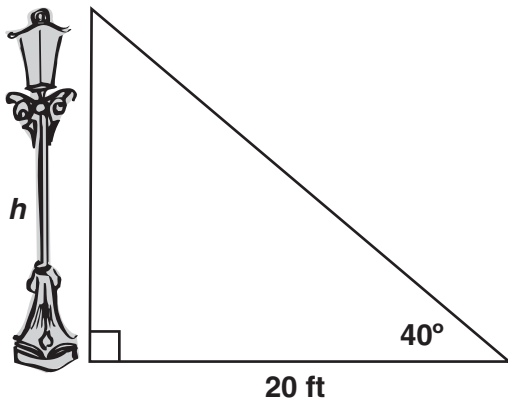

$\sin 40^\circ \approx 0.64$ $\cos 40^\circ \approx 0.77$ $\tan 40^\circ \approx 0.84$
--

- A 12.8
 B 15.4
 C 16.8
 D 23.8

CSG20047

- 65 Right triangle ABC is pictured below.

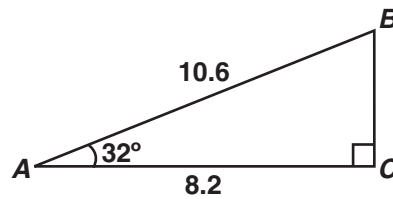

Which equation gives the correct value for BC ?

- A $\sin 32^\circ = \frac{BC}{8.2}$
 B $\cos 32^\circ = \frac{BC}{10.6}$
 C $\tan 58^\circ = \frac{8.2}{BC}$
 D $\sin 58^\circ = \frac{BC}{10.6}$

CSG10210

Released Test Questions

Geometry

- 66** In the accompanying diagram, $m\angle A = 32^\circ$ and $AC = 10$. Which equation could be used to find x in $\triangle ABC$?

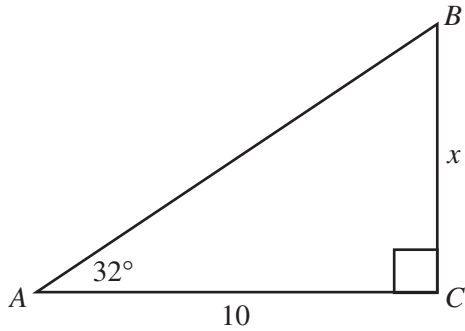

- A $x = 10 \sin 32^\circ$
- B $x = 10 \cos 32^\circ$
- C $x = 10 \tan 32^\circ$
- D $x = \frac{10}{\cos 32^\circ}$

CSG00555

- 67** The diagram shows an 8-foot ladder leaning against a wall. The ladder makes a 53° angle with the wall. Which is closest to the distance up the wall the ladder reaches?

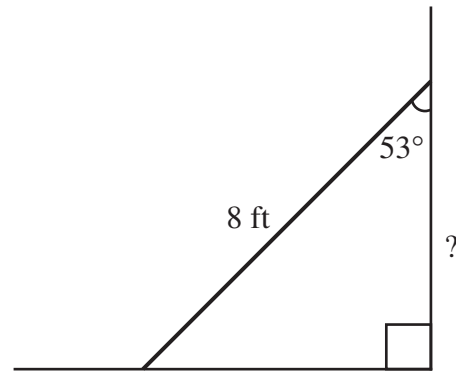

$\sin 53^\circ \approx 0.80$ $\cos 53^\circ \approx 0.60$ $\tan 53^\circ \approx 1.33$
--

- A 3.2 ft
- B 4.8 ft
- C 6.4 ft
- D 9.6 ft

CSG00342

Geometry

Released Test Questions

- 68 Triangle JKL is shown below.

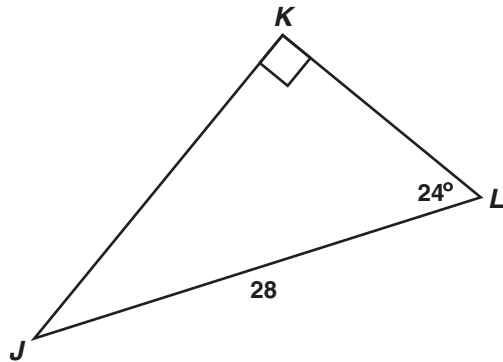

Which equation should be used to find the length of \overline{JK} ?

- A $\sin 24^\circ = \frac{JK}{28}$
- B $\sin 24^\circ = \frac{28}{JK}$
- C $\cos 24^\circ = \frac{JK}{28}$
- D $\cos 24^\circ = \frac{28}{JK}$

CSG20031

- 69 What is the approximate height, in feet, of the tree in the figure below?

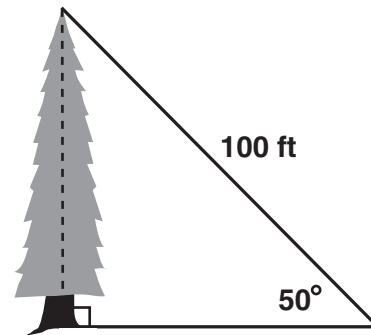

$\sin 50^\circ \approx 0.766$ $\cos 50^\circ \approx 0.643$ $\tan 50^\circ \approx 1.192$

- A 64.3
- B 76.6
- C 119.2
- D 130.5

CSG20126

- 70 If $a = 3\sqrt{3}$ in the right triangle below, what is the value of b ?

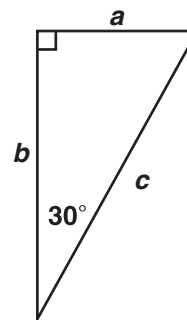

- A 9
- B $6\sqrt{3}$
- C $12\sqrt{3}$
- D 18

CSG10052

Released Test Questions

Geometry

- 71 What is the value of x in the triangle below?

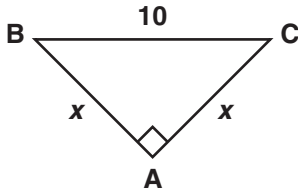

- A 5
- B $5\sqrt{2}$
- C $10\sqrt{3}$
- D 20

CSG10056

- 72 What is the value of x , in inches?

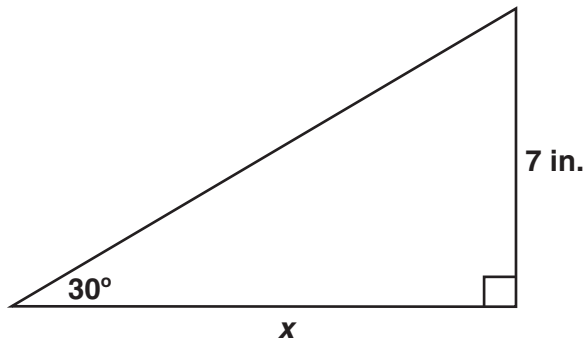

- A $7\sqrt{3}$
- B 14
- C $14\sqrt{3}$
- D 21

CSG20099

- 73 A square is circumscribed about a circle. What is the ratio of the area of the circle to the area of the square?

- A $\frac{1}{4}$
- B $\frac{1}{2}$
- C $\frac{2}{\pi}$
- D $\frac{\pi}{4}$

CSG00585

- 74 In the circle below, \overline{AB} and \overline{CD} are chords intersecting at E .

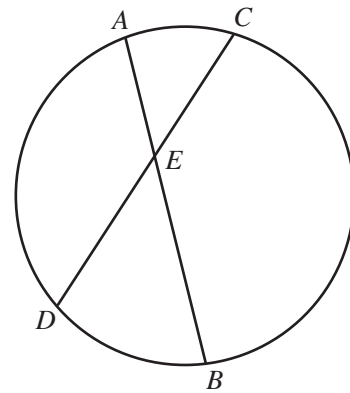

If $AE = 5$, $BE = 12$, and $CE = 6$, what is the length of \overline{DE} ?

- A 7
- B 9
- C 10
- D 13

CSG00022

Geometry

Released Test Questions

- 75 \overrightarrow{RB} is tangent to a circle, whose center is A , at point B . \overline{BD} is a diameter.

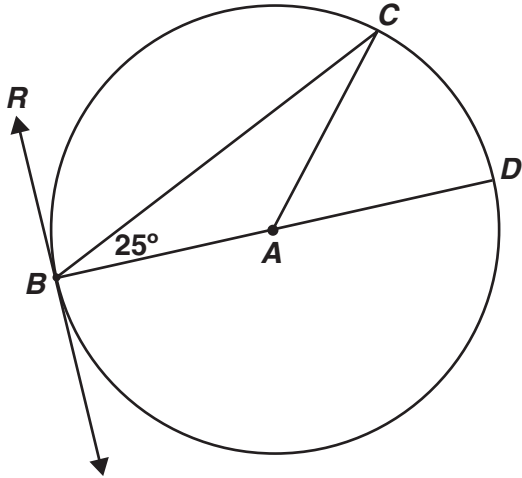

What is $m\angle CBR$?

- A 50°
- B 65°
- C 90°
- D 130°

CSG20186

- 76 In the figure below, \overline{AB} is tangent to circle O at point A , secant \overline{BD} intersects circle O at points C and D , $m\widehat{AC} = 70^\circ$, and $m\widehat{CD} = 110^\circ$.

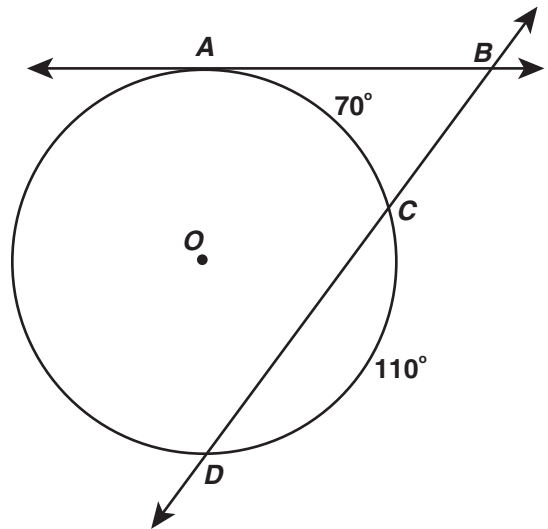

What is $m\angle ABC$?

- A 20°
- B 40°
- C 55°
- D 70°

CSG10257

Released Test Questions

Geometry

- 77** In the circle shown below, the measure of $\widehat{PR} = 140^\circ$ and the measure of $\angle RPQ = 50^\circ$.

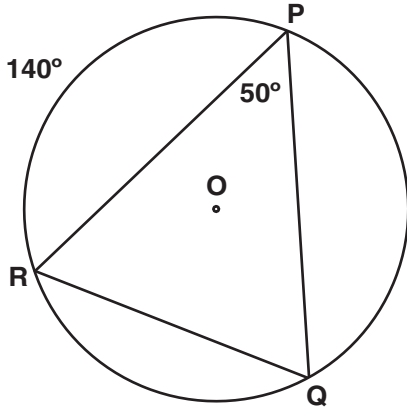

What is the measure of \widehat{PQ} ?

- A 50°
- B 60°
- C 70°
- D 120°

CSG10003

- 78** The vertices of $\triangle ABC$ are $A(2, 1)$, $B(3, 4)$, and $C(1, 3)$. If $\triangle ABC$ is translated 1 unit down and 3 units to the left to create $\triangle DEF$, what are the coordinates of the vertices of $\triangle DEF$?

- A $D(0, 1)$, $E(1, 2)$, $F(1, 3)$
- B $D(0, -1)$, $E(0, 3)$, $F(-2, -2)$
- C $D(-2, 2)$, $E(0, 3)$, $F(-1, 0)$
- D $D(-1, 0)$, $E(0, 3)$, $F(-2, 2)$

CSG00317

- 79** If triangle ABC is rotated 180 degrees about the origin, what are the coordinates of A' ?

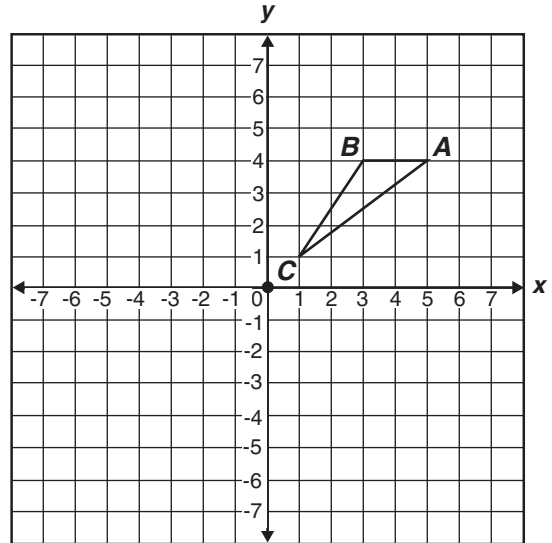

- A $(-5, -4)$
- B $(-5, 4)$
- C $(-4, 5)$
- D $(-4, -5)$

CSG10096

Geometry

Released Test Questions

- 80** Trapezoid $ABCD$ below is to be translated to trapezoid $A'B'C'D'$ by the following motion rule.

$$(x, y) \rightarrow (x + 3, y - 4)$$

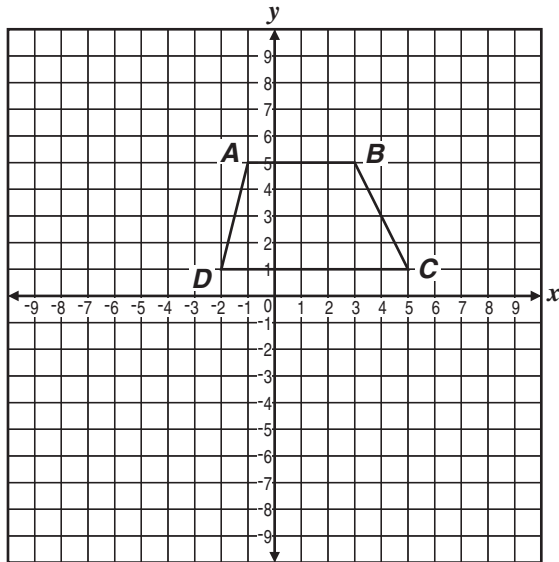

What will be the coordinates of vertex C' ?

- A $(1, -3)$
- B $(2, 1)$
- C $(6, 1)$
- D $(8, -3)$

CSG10214

Question Number	Correct Answer	Standard	Year of Release
1	A	GE1.0	2004
2	A	GE1.0	2005
3	C	GE1.0	2007
4	D	GE2.0	2003
5	D	GE2.0	2004
6	D	GE2.0	2005
7	B	GE2.0	2007
8	B	GE3.0	2003
9	D	GE3.0	2004
10	C	GE3.0	2005
11	A	GE3.0	2006
12	D	GE4.0	2003
13	C	GE4.0	2004
14	C	GE4.0	2005
15	B	GE4.0	2005
16	D	GE4.0	2006
17	A	GE4.0	2007
18	D	GE4.0	2007
19	A	GE5.0	2003
20	A	GE5.0	2004
21	C	GE6.0	2003
22	B	GE6.0	2007
23	C	GE7.0	2003
24	B	GE7.0	2004
25	C	GE7.0	2005
26	D	GE7.0	2006
27	A	GE7.0	2006
28	D	GE8.0	2003
29	C	GE8.0	2005
30	C	GE8.0	2006
31	C	GE8.0	2007
32	A	GE9.0	2006
33	D	GE9.0	2006
34	C	GE10.0	2003
35	A	GE10.0	2004

Question Number	Correct Answer	Standard	Year of Release
36	<i>C</i>	GE10.0	2005
37	<i>B</i>	GE10.0	2006
38	<i>B</i>	GE10.0	2007
39	<i>B</i>	GE10.0	2007
40	<i>D</i>	GE11.0	2004
41	<i>A</i>	GE11.0	2005
42	<i>D</i>	GE12.0	2003
43	<i>A</i>	GE12.0	2003
44	<i>C</i>	GE12.0	2005
45	<i>A</i>	GE12.0	2005
46	<i>D</i>	GE12.0	2006
47	<i>C</i>	GE12.0	2007
48	<i>A</i>	GE13.0	2005
49	<i>A</i>	GE13.0	2006
50	<i>B</i>	GE13.0	2007
51	<i>C</i>	GE14.0	2004
52	<i>B</i>	GE15.0	2003
53	<i>A</i>	GE15.0	2004
54	<i>A</i>	GE16.0	2003
55	<i>D</i>	GE16.0	2004
56	<i>D</i>	GE16.0	2006
57	<i>D</i>	GE16.0	2007
58	<i>B</i>	GE17.0	2004
59	<i>C</i>	GE17.0	2005
60	<i>D</i>	GE17.0	2006
61	<i>A</i>	GE17.0	2007
62	<i>A</i>	GE18.0	2003
63	<i>C</i>	GE18.0	2004
64	<i>C</i>	GE18.0	2006
65	<i>C</i>	GE18.0	2007
66	<i>C</i>	GE19.0	2003
67	<i>B</i>	GE19.0	2005
68	<i>A</i>	GE19.0	2006
69	<i>B</i>	GE19.0	2007
70	<i>A</i>	GE20.0	2004

Question Number	Correct Answer	Standard	Year of Release
71	<i>B</i>	GE20.0	2005
72	<i>A</i>	GE20.0	2007
73	<i>D</i>	GE21.0	2003
74	<i>C</i>	GE21.0	2004
75	<i>B</i>	GE21.0	2005
76	<i>C</i>	GE21.0	2006
77	<i>D</i>	GE21.0	2007
78	<i>D</i>	GE22.0	2003
79	<i>A</i>	GE22.0	2004
80	<i>D</i>	GE22.0	2006